

# PROGRAMMABLE PROCESS MONITORS

## USER'S MANUAL

### PPM SERIES



*KAIF DIGITAL CORPORATION  
7678 E. GREENWAY ROAD, #103,  
SCOTTSDALE, AZ 85260*

TEL. NO: (480) 607-3100  
FAX NO: (480) 607-3101

<b>SPECIFICATIONS .....</b>	<b>3</b>
<b>DESCRIPTION.....</b>	<b>4</b>
<b>SET UP .....</b>	<b>4</b>
SETUP ENTRY: .....	4
SETUP EXIT: .....	4
PROGRAMMING GROUP SELECTION: .....	5
<b>SCALING .....</b>	<b>5</b>
DECIMAL POINT: .....	5
HIGH SCALE: .....	5
LOW SCALE: .....	5
OFFSET: .....	6
TARE: .....	6
<b>PROGRAM LIMITS: .....</b>	<b>6</b>
PROCESS LIMITS (1 THRU 4): .....	6
SELECTION OF LIMIT 3 AS PROCESS OR RATE LIMIT: .....	6
PROGRAMMING LIMIT 3:.....	6
<i>As Process Limit:</i> .....	6
<i>As Rate Limit:</i> .....	6
SELECTION OF LIMIT 4 AS PROCESS OR DEVIATION LIMIT:.....	7
PROGRAMMING LIMIT 4:.....	7
<i>As Process Limit:</i> .....	7
<i>As Deviation Limit:</i> .....	7
TIMERS 1 AND 2:.....	7
RELAY DEADBAND:.....	7
CONFIGURING LIMITS NORMALLY OPEN/NORMALLY CLOSED: .....	7
RELAY LATCHING/NON LATCHING: .....	7
AUDIO ALARM ON/OFF: .....	8
<b>PROGRAM SYSTEM:.....</b>	<b>8</b>
DISPLAY OPTION:.....	8
FLASH TIME: .....	8
ENGINEERING UNITS: .....	8
SETPOINT:.....	8
RATE TIME-BASE: .....	9
REMOTE TARE/HOLD: .....	9
INPUT TYPE: .....	9
INPUT RANGE: .....	9
<b>SET UP FLOW CHART:.....</b>	<b>10</b>
<b>MAX. AND MIN. READINGS (PEAKS).....</b>	<b>11</b>
DISPLAYING: .....	11
RESETTING: .....	11
<b>RATE .....</b>	<b>11</b>
<b>TIME.....</b>	<b>11</b>
DISPLAYING: .....	11
RESETTING: .....	11
<b>PROCESS CHANGE .....</b>	<b>12</b>
DISPLAYING: .....	12
RESETTING: .....	12
<b>SCALING .....</b>	<b>12</b>

<b>OFFSET</b> .....	<b>12</b>
<b>TARE</b> .....	<b>13</b>
<b>LIMITS</b> .....	<b>13</b>
PROCESS LIMITS: .....	13
<i>Displaying:</i> .....	13
<i>Resetting:</i> .....	13
TIMER LIMITS:.....	14
<i>Displaying:</i> .....	14
<i>Resetting:</i> .....	14
<b>ALARM OUTPUTS</b> .....	<b>14</b>
STATUS:.....	14
ELECTRO-MECHANICAL RELAY OPTION: .....	14
<i>Figure 1. Electro-mechanical Relays Hookup Example</i> .....	14
OPEN COLLECTOR OPTION .....	15
<i>Figure 2. Open Collector Hookup Example</i> .....	15
<b>HOLD FUNCTION</b> .....	<b>15</b>
<b>SAVING PARAMETER:</b> .....	<b>15</b>
<b>POWER</b> .....	<b>15</b>
<b>FIGURE 3. REAR VIEW OF PPM INSTRUMENT</b> .....	<b>16</b>
<b>OUTPUT CONNECTOR PIN ASSIGNMENT:</b> .....	<b>16</b>
<b>TROUBLE SHOOTING</b> .....	<b>17</b>
FACTORY DEFAULT SETTINGS FOR VOLTAGE, CURRENT AND MILLIVOLT:.....	17
ERROR MESSAGES: .....	17
<b>MOUNTING</b> .....	<b>18</b>
FIGURE 4. PANEL CUTOUT DIMENSIONS .....	18
<b>WARRANTY</b> .....	<b>19</b>

# SPECIFICATIONS

(typical @ 25 C and rated supply voltage unless otherwise specified).

## STANDARD INPUT:

- \* 4 - 20 MA, 10 - 50 MA, 0 - 5 VDC, 0 - 10 VDC

## EXTERNAL HOLD:

- \* An external low level signal applied to the HOLD pin on the rear connector will initiate hold function.

## ANALOG TO DIGITAL CONVERSION:

- \* 4 1/2 Digit A/D conversion.
- \* Dual slope integrating converter.
- \* Conversion Rate: seven conversions per second typical.

## INPUT IMPEDANCE

- \* 100 OHMS for 4-20 ma            40 ohms for 10-50 ma
- \* 1 megohm for voltage input

## POWER REQUIREMENTS (choice of three supply ranges):

- \* 120 VAC -- 60Hz
- \* 240 VAC -- 50Hz
- \* 7.5 VDC -- 12VDC @ 900 ma

## DIMENSIONS:

- \* Case: 3.60" x 1.75" x 7"
- \* Bezel size: 4.40" x 2.25" x 0.45"
- \* Extruded Aluminum enclosure

## DISPLAY:

- \* Red 7-segment LED display, 0.39 inch (10mm) digit height.
- \* Negative Polarity indication.
- \* Over range indication: HELP.
- \* Display Test: Briefly displays 8888 on power up.

## RELAYS (optional):

- \* Single pole double throw, 1 Ampere @ 28VDC or 0.5 amp @ 120VAC, resistive.

## OPEN COLLECTOR:

- \* Open collector drive: 5vdc @ 50ma each (maximum of six outputs)

## SCALING:

- \* Programmable from 1-30000 units

## OFFSET:

- \* Programmable from 0-30000 units

## TARE:

- Programmable and is equal to the value of programmed scale.

## DESCRIPTION

The PPM series of instruments are micro-processor based intelligent monitors that are capable of performing several tasks in addition to displaying the process variable. The micro-processor technology used in the system design has provided these instruments a cost and performance edge that is simply not possible with analog systems.

Various process parameters monitored by the system can be displayed by pushing appropriate keys on the front panel e.g. LMT1, Peak etc. The respective parameter will be displayed for as long as the key is kept pressed. Alternatively, if the key is pressed and then released, the monitor will display the particular parameter briefly and then go back to process variable display mode. Each key works either by itself or in combination with other keys to perform various functions.

The system has a warning mode where it displays '**HELP**' any time a wrong key or sequence of keys is pressed. Also in case of over/under range the 'HELP' sign will be displayed constantly.

The system has six limit alarms, four for process and two timers. One of the four process limits can be figured to work as rate limit (LIMIT 3) while another process limit (LIMIT 4) can be programmed to work as deviation limit. All limit alarms can be operated in two different modes. The first one is non latching mode in which the relays reset automatically as soon as process, rate or deviation falls below the limit (minus the relay dead-band). The second one is latching mode. In this mode the relays will stay energized even after the parameter falls below the programmed limit. They can be reset manually only.

The very first thing required before monitoring the process would be to configure the personality of the unit to fit your particular application. This will allow the process variable to be read in a more comprehensible manner. Configuration is done by going into the SETUP mode and programming such parameters as SCALE, OFFSET, RELAY DEADBAND etc.

## SET UP

### *Setup Entry:*

To get into setup mode, press the TIME/SET UP key twice. This will get you into the setup mode and will be indicated by displaying of the message '**ENTR PC**' (for 'Enter PassCode'). At this point enter the pass code for your system. The pass code entry, which is four digits long, keeps unauthorized personnel from changing system parameters. Each key is marked with a small digit in one of its corners. Pass-code is a combination of these digits and for this system it is **3254**. Three attempts at entering the correct pass-code are allowed. Any time a wrong digit is entered the display will read 'HELP'. If a person fails to enter correct pass-code in three attempts, the system automatically exits SETUP mode. To try again, you have to get into the setup mode by pushing '**SETUP**' key twice.

### *Setup Exit:*

To exit SETUP mode at any point, simply push RESET key and hold it till display reads 'SAVING' (SAVING indicates that programmed parameters are being saved in Electrically erasable programmable read only memory -- EEPROM).

## ***Programming Group Selection:***

On entering correct passcode, setup procedure starts. The very first step will let you select one of the three groups of parameters that you can program. Three available groups are: 1) SCALING 2) PROGRAM LIMITS 3) PROGRAM SYSTEM. Each group will let you program various parameters as shown below:

### **SCALING**

1. High Scale
2. Low Scale
3. Offset
4. Tare

### **PROGRAM LIMITS**

1. Process Limit1
2. Process Limit2
3. Setup limit 3 for Rate/Process
4. Process Limit 3
5. Setup Limit4 for Process/Deviation
6. Process Limit 4
7. Timer 1 Limit
8. Timer 2 Limit
9. Deadband for limits
9. Limits Normally open/close (1 Thru 4)
10. Limits Latching/Non Latching

### **PROGRAM SYSTEM**

1. Display Options
2. Flash Time
3. Engineering units
4. Program Setpoint
5. Remote Tare/Hold
6. Input Type
7. Input Range

Push ^v key to move from one programming group to the next. When a desired group is displayed, push SETUP key to select it.

## **SCALING**

### ***Decimal point:***

Decimal point mode is indicated as '**dp 9999**' (dp stands for DECIMAL POINT). Push ^v key to program decimal point. Each push on the ^v key moves the decimal point to the next position. After 9.999 the display will go to 9999. When proper decimal point position has been obtained push SETUP key to go to the next mode.

### ***High Scale:***

High scale mode is indicated by a brief display of the message '**HI SCLE**' followed by high scale value. The least significant digit (right most digit) will be flashing. The flashing indicates that pushing ^v key will increment or decrement that particular digit. Pushing ^v key once and holding it down will increment the flashing digit. Releasing the ^v key and pushing it again immediately ( and then holding it in) will start decrementing the display. The desired number can be programmed by toggling the ^v key. To move to the next significant digit push <NXT> key, and to increment or decrement it, use ^v key. After obtaining a new high scale value (or to retain the current one) push SETUP key to get to the next mode.

### ***Low Scale:***

Low Scale mode is indicated by the display first flashing '**LO SCLE**' and then the pre-programmed value of low scale. Again, to change the flashing digit value use ^v key. To change any other digit, use <NXT> key to make that digit flash and then use ^v key to change its value. After obtaining a new value (or to retain the present value) push setup key. This will also get you into the next function.

### ***Offset:***

Next configurable function is offset and is indicated by the message '**OFFSET**' followed by current offset value. To change the value of flashing digit press ^v key. To move the flashing digit, push <NXT> key. After programming the desired value of offset, push the "SETUP" key to get to the next function.

### ***Tare:***

Tare mode is indicated by the word '**TARE**' followed by current Tare value. To change the value of flashing digit, press ^v key. To move the flashing digit, push <NXT> key. After programming the desired value of 'TARE' push '**SETUP**' key (Minimum programmable tare is zero, maximum is equal to the scale value). This will take us back to the very beginning of SETUP mode with the display showing the message '**SCALING**'.

## **PROGRAM LIMITS:**

### ***Process Limits (1 thru 4):***

If selection made from programming groups is for 'PROG LT' then the very first parameter programmed is process limit 1. This is indicated by the message '**PrG LT1**' followed by pre-programmed value of the limit. Again, use <NXT> key to move flashing to the next digit and ^v key to increment/decrement the value of the flashing digit.

The following steps are very similar to the above (i.e. for Limits 2,3 and 4 and also if Limits 3 and 4 are setup as process limits) and allow you to enter process limits 2 through 4. However, limits 3 and 4 can be configured to work as rate and deviation limits, respectively. Therefore, after programming limit 2, the next step takes us into selection of limit 3 as rate or process limit.

### ***Selection of Limit 3 as Process or Rate Limit:***

This step comes after programming Limit 2 and is indicated by the message '**LT3 RTE**' (if Limit 3 is setup as Rate limit) or '**LT3 Pr**' (if Limit 3 is setup as Process limit). Alternate selection can be made by pushing ^v key. Push **SETUP** key after making the selection.

### ***Programming Limit 3:***

#### ***As Process Limit:***

If Limit 3, in the above step, was configured as a Process limit, then the message displayed on entering this mode will be '**PrG Lt3**'. This will be followed by displaying of current value of Limit 3 . Use <NXT> key to move flashing to the next digit and ^v key to increment/decrement the value of the flashing digit.

#### ***As Rate Limit:***

If Limit 3, in the above step, was configured as a Rate limit, then the message displayed on entering this mode will be '**RATE Lt**'. This will be followed by displaying of current value of Limit 3 . Use <NXT> key to move flashing to the next digit and ^v key to increment/decrement the value of the flashing digit.

### ***Selection of Limit 4 as Process or Deviation Limit:***

This step comes after programming Limit 3 and is indicated by the message '**LT3 Pr**' (if Limit 3 is setup as Process limit) or '**LT3 dEN**' (if Limit 3 is setup as deviation limit). Alternate selection can be made by pushing ^v key. Push **SETUP** key after making the selection.

### ***Programming Limit 4:***

#### ***As Process Limit:***

If Limit 4, in the above step, was configured as a Process limit, then the message displayed on entering this mode will be '**PrG Lt4**'. This will be followed by displaying of current value of Limit 4 . Use <NXT> key to move flashing to the next digit and ^v key to increment/decrement the value of the flashing digit.

#### ***As Deviation Limit:***

If Limit 4, in the above step, was configured as a Deviation limit, then the message displayed on entering this mode will be '**dEVN Lt**'. This will be followed by displaying of current value of Limit 4 . Use <NXT> key to move flashing to the next digit and ^v key to increment/decrement the flashing digit.

### ***Timers 1 and 2:***

This mode lets you enter values for timer 1 and 2. The display will read '**TR1 LT**' (for timer 1 limit) and '**TR2 LT**' (for timer 2 limit) followed by current programmed value of each of the timers. To change the value use <NXT> key in conjunction with the ^v key. Once done, push the **SETUP** key to go to the following parameter.

### ***Relay Deadband:***

The parameter programmed after timers is limit deadband. The display will first read "**DEAD BD**" and then show the value of previously programmed dead-band. To change the value of flashing digit, press ^v key. To move flashing digit, push <NXT> key. After programming the desired value of "dead-band" push '**SETUP**' key to get to the next function.

### ***Configuring Limits Normally open/Normally Closed:***

Following relay deadband, the alarm outputs are configured as normally closed or normally open. This will be indicated as '**LT1 N.O.**' ( if limit 1 is programmed as normally open) or '**LT1 N.C.**' (if limit 1 is programmed as normally closed). To make an alternate selection, push the ^v key. After selecting or to retain current setting, push the **SETUP** key. The following three steps are similar to the last step and in it limits 2 through 4 are setup as normally open or normally closed.

### ***Relay Latching/non Latching:***

The next function is configuration of relays as latching or non-latching. In non-latching mode the relays will reset automatically when the Process variable drops below the programmed limit. In the latching mode once the relays are energized they have to be reset manually even though the process variable might have fallen below the limit ( latching/non-latching mode is only for process, rate and deviation limits). If the system is in latching mode the display will read '**LATCH**'. Alternately, the display will read '**NON LCH**' (for "non latching"). To get the alternate mode push ^v key. To retain present mode push **SETUP** key.



## ***Audio Alarm On/Off:***

This unit supports an audio alarm which comes on when ever a limit value is exceeded. This alarm can be turned On or Off, as desired. The selection is made by pushing ^v key. If the alarm is ON, the display will read '**ALR ON**' (Alarm On). Alternately, it will display '**ALR OFF**' (for 'Alarm Off'). Push **SETUP** key after desired setting is displayed. This last push on **SETUP** key will also take you back to the very beginning of setup mode.

## **PROGRAM SYSTEM:**

### ***Display option:***

This is the very first step in programming the system and in this step, display option is selected. One of the following options can be selected:

- |                                |                  |                            |                  |
|--------------------------------|------------------|----------------------------|------------------|
| 1) Display process variable    | <b>(PROCESS)</b> | 5) Display High Peak       | <b>(HIGH PT)</b> |
| 2) Display set-point deviation | <b>(SP DEN)</b>  | 6) Display Low Peak        | <b>(LO PT)</b>   |
| 3) Display rate                | <b>(RATE)</b>    | 7) Elapsed time indication | <b>(ELPSD T)</b> |
| 4) Display process change      | <b>(PR CNG)</b>  | 8) Scan all parameters     | <b>(SCAN)</b>    |

To make a selection push ^v key. The display will indicate the selected option as indicated in parenthesis against each option. Once the desired display mode has been selected, push the **SETUP** key.

### ***Flash Time:***

Flash time is the time inbetween the message which indicates the active display parameter and its value e.g. if the selected display option in the above step was '**PROCESS**', then the display will periodically display the message '**PROCESS**' to indicate that the displayed value is process variable. Flash time is in seconds. Thus if the programmed flash time is 20, then process value will be displayed for 20 seconds before the message '**PROCESS**' will be displayed. Use ^v and <NXT> keys to get the desired time. On finishing, push **SETUP** key.

### ***Engineering Units:***

This step lets you program three alphabet long engineering units e.g. PSI, YDS, FT etc. On entering this mode, the active alphabet will be flashing. To change it, push ^v key and keep it pushed till the desired alphabet shows up. Toggle the ^v key to go up or down in the alphabets. Use <NXT> key to move to the other alphabets and then use ^v key to change them. Programmable alphabets are:

A,B,C,D,E,F,G,H, I,J,L,N,O,P,Q,R,S,T,U,Y

After obtaining the desired units, push **SETUP** key and this will take you to setting up the next parameter.

### ***Setpoint:***

Setpoint entry mode is indicated by the message '**SETPT**' followed by the display of current setpoint value e.g. 20.00. To enter new setpoint use <NXT> key in conjunction with ^v key. Once done entering new value, or to retain the previous value, push the **SETUP** key.

### ***Rate Time-Base:***

This step is for programming time-base for calculation of Rate. Units of time-base are seconds. Again, the active digit will be flashing. To change the value, push ^v key. To activate another digit for change, use <NXT> key. On finishing, push **SETUP** key.

### ***Remote Tare/Hold:***

Remote Tare/Hold feature lets you select between the remote switch being used for resetting tare or holding the reading on the display. The display will read '**RT TARE**' (for remote Tare) or '**RT HOLD**' ( for remote display hold feature ). To get the alternate mode push ^v key. Else push **SETUP** key and this will get you into the next function.

### ***Input Type:***

The step after remote Tare/Hold is selecting the input type. The display will first read '**IP TYPE**' followed by the current selection. Various input types are:

- |              |                      |
|--------------|----------------------|
| i) CURRENT   | 4-20MA Signal        |
| ii) VOLTAGE  | 0-10Vdc, 0-5Vdc etc. |
| iii) LO VOLT | 0-100mv etc.         |

To make a selection push ^v key. After selection push **SETUP** key to go to the next step.

### ***Input Range:***

The following step is the last step in this process. This is where you program the input range of your signal. On entering this mode, the display will first read "**IP RNGE**" (for input range) followed by the indication of current input range. Following **RANGE** values should be entered for various inputs:

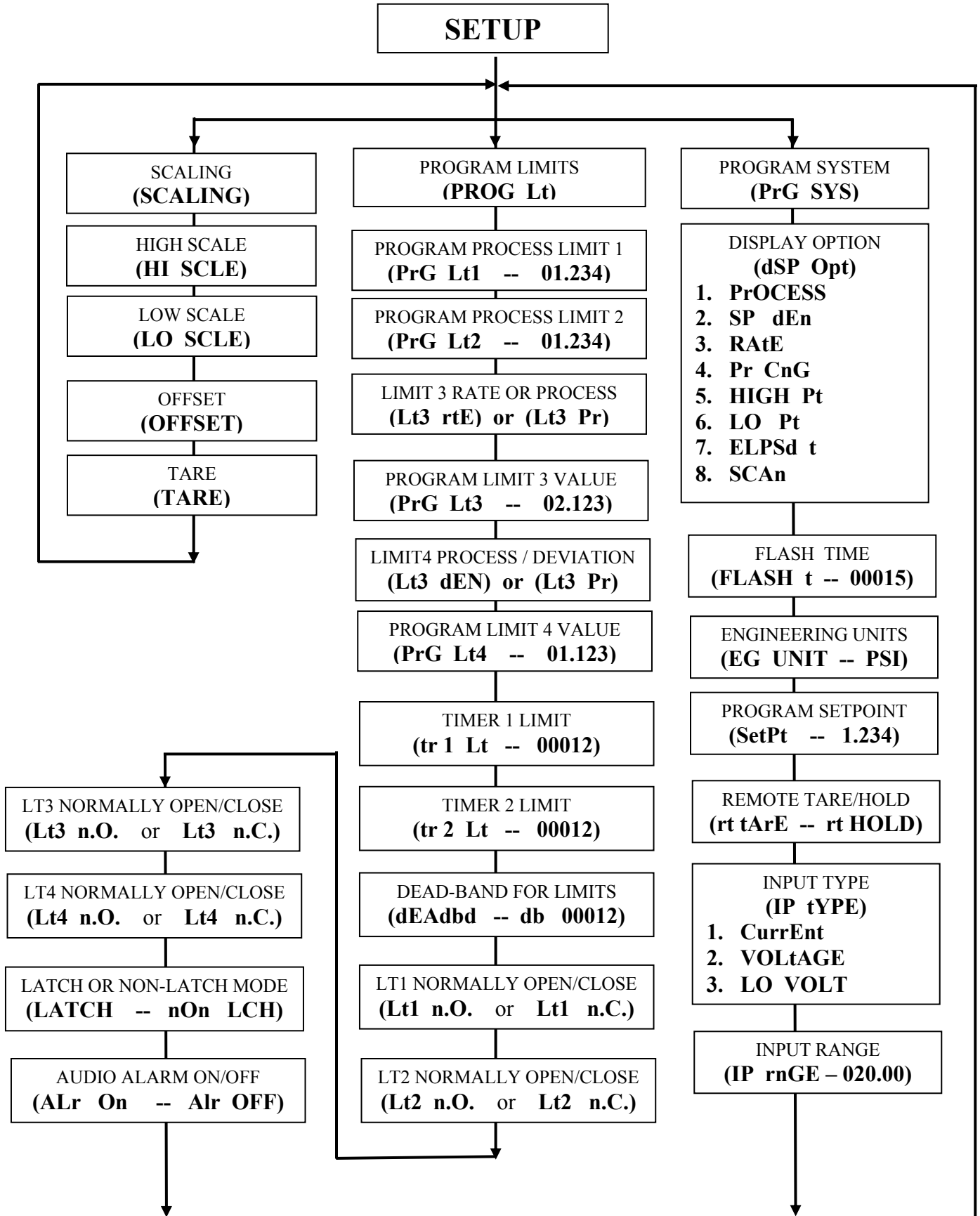
<u>INPUT TYPE</u>	<u>INPUT RANGE</u>	<u>PROGRAMMED VALUE</u>
VOLTAGE	0-10VDC Signal	10.000
VOLTAGE	0-5VDC Signal	5.000
CURRENT	4-20ma Loop Current	20.00
LO VOLT	0-100 Millivolt Signal	100.0

If the end user recalibrates any of the process inputs to different values he/she must enter new values here.

**NOTE: THE INPUT TYPE IS SET ACCORDING TO THE MODEL ORDERED. SIMPLY MAKING A SELECTION WILL NOT CONVERT THE UNIT FROM A CURRENT TO A VOLTAGE OR A MILLIVOLT UNIT. THIS IS A HARDWARE CHANGE AND MUST BE SELECTED AT THE TIME OF PLACING THE ORDER.**

After entering the desired input range, push the **SETUP** key. This will take us back to the very beginning of setup mode with the display reading **SETUP** briefly and then **SCALING**. To exit at this point push and hold **RESET** key till the display shows '**SAVING**'.

# SET UP FLOW CHART:



## MAX. AND MIN. READINGS (PEAKS)

### *Displaying:*

To display the peak values of Process variable push Peak key once and let go. The display will first indicate '**HIGH Pt**' briefly and then the value of the highest Process variable value monitored by the system. A second push while high peak is being displayed will bring up low peak value on the display. The value will be preceded by the message '**LO PT**'..

### *Resetting:*

To reset the peaks to the present value of Process Variable simply push the PEAK key once and keep it pushed. The display will briefly indicate '**HIGH Pt**' and then the value of the high peak. With the PEAK key still pushed, go on to press the RESET key. On resetting the display will indicate the new value of high peak. To reset the low peak value, get the system in low peak display mode. This is done by pushing the PEAK key twice. Do not release the PEAK key after the second push. While keeping the PEAK key pushed, press the RESET key. This will reset the low peak to current Process Variable value.

## RATE

The PPM unit keeps track of the rate of process change and can be displayed by pushing the key labeled '**RATE**'. The display first reads '**RATE**' followed by the rate value that was monitored over the last time base. The maximum rate of change displayable is equal to the value of High Scale. If the calculated rate is negative, it will be indicated so by a negative sign. Rate time base, which is in seconds, is programmable and is set during SETUP of the unit.

## TIME

### *Displaying:*

The system keeps track of the process run time in hours, minutes and seconds. The display format is **HH.MM.SS** (HH = Hours, MM = Minutes, SS = Seconds). To display the elapsed time since the system was turned on or last reset, push the **TIME** key. The display will first read '**ELPSd t**' (for ELAPSED TIME) and then the value of elapsed time.

### *Resetting:*

To reset the timing and start it all over again, first push the **TIME** key and while keeping it pushed press the '**RESET**' key. The time will reset and the display will read '**RESET**' following which the unit will start tracking time from zero.

NOTE: On resetting, the time relays, if energized, will de-energize and would be activated again when the programmed amount of time has elapsed.

## PROCESS CHANGE

### *Displaying:*

The system will constantly monitor the total amount of change in process variable since start or last reset. This change is displayable in engineering units by pushing the '**PR CNG**' key.

This function is useful in tracking the change that has taken place in the process e.g. in a tank containing 300 gallons of water, an addition of 200 gallons will show that the total amount of water is 500 gallons. On pushing the '**PR CNG**' key the display will indicate 200 gallons as the total change. Now assume that 400 gallons of water is pumped out. The total amount of water left in the tank would now be indicated as 100 gallons. The change that has taken place in the total volume of water from its original 300 gallons can be displayed by pushing the "PR CNG" key and it would be 200 gallons.

### *Resetting:*

To start tracking the change from a new point, the Process change being indicated can be reset to zero. To do so, push the '**PR CNG**' key twice and keep it pushed. The display will flash the present change value three times and then reset it to zero (keep the "PR CNG" key pushed till the display shows zero or close to zero). This flashing feature is provided so that if '**PR CNG**' key gets pushed twice accidentally while trying to display the process change it would provide a chance to get out of reset mode without actually resetting the reading. Therefore, if '**PR CNG**' key is released any time before the three flashes, the current reading of "Process Change" will be retained.

## SCALING

Scaling is useful in reading the sensor output directly in engineering units e.g. a load cell putting out 4 - 20 ma signal can be scaled to read 0 - 4000 pounds of load.

Scale is entered as two different values i.e. High Scale and low Scale. High scale corresponds to the maximum output of the transducer and low scale to low output. e.g. For a 0-5V transducer if it is desired to read 200 units at 0VDC and 3000 units at 5VDC output then set low scale equal to 200 and high scale to 3000. The PPM unit will linearly scale the transducer output. For a transducer with 4-20ma the low scale reading can be obtained at the programmed offset value. For instance if offset is set to 4.00, then the low scale reading will be obtained when the unit sees a 4.00ma signal from the transducer.

Scaling is obtained during setup mode and immediately follows the setting up of decimal point. Maximum programmable high scale is from 1-30000 and low scale from 0-high scale value.

Scaling can be programmed and displayed in SETUP mode only (look under setup).

## OFFSET

The system provides the capability of programmable offset. This is useful if a certain amount of input from the transducer is required to read zero e.g. for a 4-20ma input, 4ma can be made to read zero.

Offset can be programmed and displayed in the SETUP mode only (look under setup).

## TARE

Tare function is used for taking out a preset amount of process variable from the total reading e.g. if we are measuring weight of a certain product being put in a container but do not want the weight of the container to show on the display, then enter the weight of the container as tare value. The PPM unit will then automatically subtract the weight of the container from the total reading and display the weight of the product only.

Desired Tare is entered during SETUP procedure. Also, while entering Tare in SETUP, pushing the 'TARE' key will take the reading at that instant and store it as a new tare value.

PPM units also allow remote resetting of the TARE by using an external switch. This switch is connected between pins 13 and 14 on the rear connector. When ever the remote switch is activated, PPM will take the reading at that instant and store it as a tare value. As long as the switch is kept activated the unit will keep taking the reading as a new tare value.

For the remote switch to accept the reading as tare, the unit must be setup as such. This is done during the setup mode. Alternatively the same switch can be used to hold the display. Therefore, make sure that during setup when configuring tare/hold, the display must read '**RT TARE**'.

## LIMITS

### *Process Limits:*

#### *Displaying:*

The LIMITS key is used for displaying Process Variable limits. Pushing the LIMITS key twice will briefly display **PR LT1** (first push displays RATE) and then go on to show the process based limit 1 value. Each consecutive push there after will display '**PR LT2**' and programmed limit 2 value, '**PR LT3**' and its value, '**PR LT4**' and its value. If limits 3 and 4 are configured as rate and deviation limits respectively, then the third push will display '**rATE Lt**' followed by rate value and the fourth push will display '**dEVn Lt**' followed by deviation limit value. The programming of process limits is done during setup procedure (look under SETUP).

#### *Resetting:*

Once energized, alarms can be reset in two different ways --- automatically or manually (non latching or latching). In non latching mode the alarm outputs will de-energize on their own when the process variable drops below the limit value. In the latching mode they stay energized even if the process variable drops below the limit. To reset the energized outputs in latching mode, first make the display indicate the limit that needs to be reset e.g. '**PR LT2**', by pushing the '**LIMITS**' key (as described above under 'Displaying'). Next, while keeping the 'LIMITS' key pushed, go on to push the '**RESET**' key. The respective alarm output will de-energize and the system will indicate so by displaying RLY RST. Selection of latching or non-latching mode for outputs is done during setup.

## ***Timer Limits:***

### ***Displaying:***

To display timer limits, first push the **TIME** key. While still in this mode go on to push **LIMITS** key. The display will briefly show **TR1 LT** (for timer 1 Limit) and then the previously programmed value. Pushing the **LIMITS** key one more time will display **TR2 LT** followed by pre-programmed timer 2 value. Programming of timer limit values is done during setup procedure (for details look under **SETUP**). Timer values are can also be displayed without pushing 'TIME' key. **TR1 LT** and **TR2 LT** is displayed following Process limit 4 (or deviation limit) value, as described above under Process Limits.

### ***Resetting:***

The two timer outputs will reset as soon as the time is reset to zero. Time is reset to zero by pushing **TIME** and **RESET** keys simultaneously.

## **ALARM OUTPUTS**

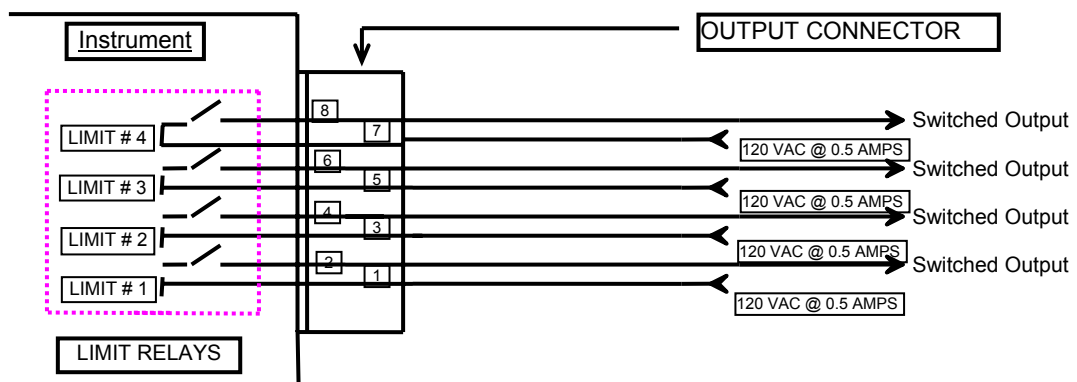
### ***Status:***

The system has optional process and timer alarm outputs that are activated when the limit is achieved on each one of them. The alarms can be programmed as normally open or normally closed (see **SETUP**). The status of these is indicated on the front panel by the LEDs. When ever an alarm is activated the respective LED is turned on.

### ***Electro-Mechanical Relay Option:***

PPM units can be ordered with either open collector outputs or electro-mechanical relays. (Check model number printed on the unit for option). If ordered with relays, then these relays are programmed during Setup to operate as either Normally Open (NO) or Normally Closed (NC). The default setting is Normally Open. Each of these limit relays provides a switched output whenever a limit is reached. The maximum rating for a 120Vac unit is 120Vac @ 0.5 amp or 28 Vdc @ 1.0 amp.

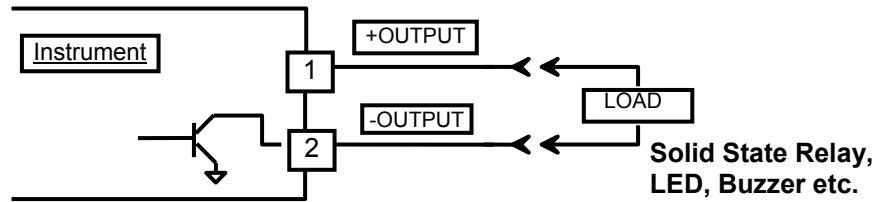
***Figure 1. Electro-mechanical Relays Hookup Example***



## ***Open Collector Option***

Whenever a limit is reached an open collector output provides a 5 Vdc signal at 50ma. on the output connector, e.g... Limit 1 provides its 5 volt output signal between pins 1 and 2.

***Figure 2. Open Collector Hookup Example***



## **HOLD FUNCTION**

The hold function allows to freeze the Process Variable reading in the display window indefinitely till the Hold pin is active. This function is activated by tying Hold pin (pin13) to the digital ground pin (pin 14) through a relay or switch.

## **SAVING PARAMETER:**

PPM saves all the programmed parameters in an EEPROM (electrically erasable programmable read only memory). An EEPROM stores the programmed parameters even when the power is removed from the unit. However, it is important to note that if the parameters are being changed during setup, they must be saved in the EEPROM by pressing and holding **RESET** key till the display reads 'SAVING'. If the parameters are **NOT** saved and the power is removed from the unit, any newly changed values will be lost (the unit will maintain the old values).

## **POWER**

Power connection should be made to the three terminal connector as shown in figure 3. Also, make note that it is very important that the power line inputs and the power ground are not switched. Doing so will permanently damage the instrument. Refer to the drawing for proper connections. For convenience, the printed circuit board is labeled **L1 L2 GND** on the under side of three terminal power connector.

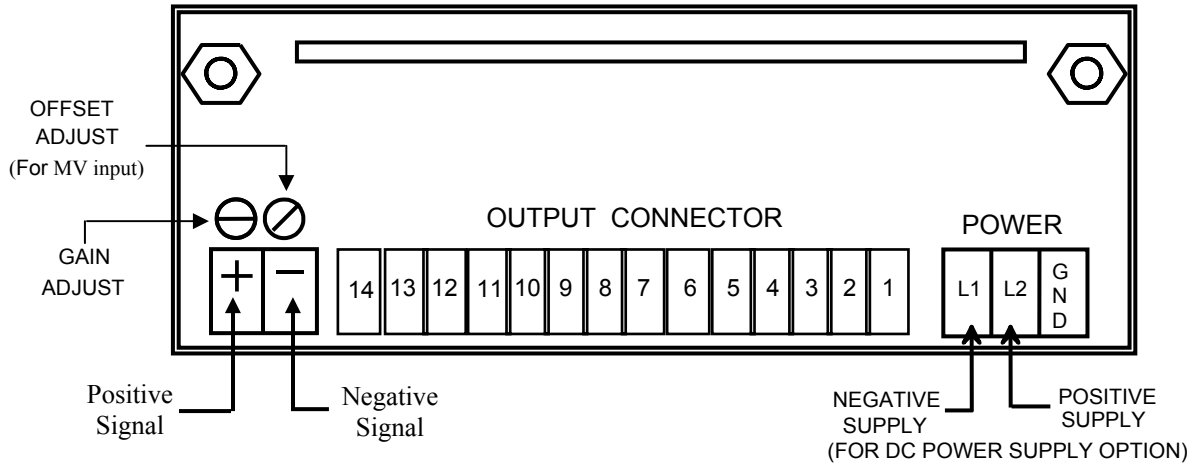
For instruments with the 12Vdc power option, refer to Figure 3.

**NOTE: WHILE MAKING POWER CONNECTION TO THE UNIT, MAKE SURE THAT AC POWER LINE L1 OR L2 IS NOT ACCIDENTALLY CONNECTED INTO THE GROUND (GND) TERMINAL. THIS WILL RESULT IN PERMANENT DAMAGE TO THE INSTRUMENT.**

**DOUBLE CHECK THE CONNECTIONS BEFORE APPLYING POWER!!**

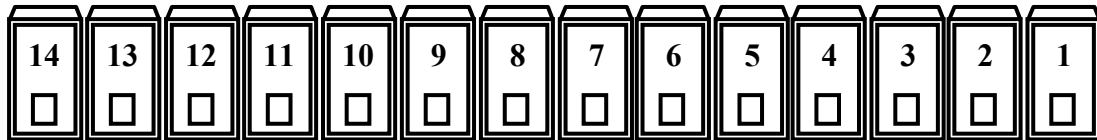


**FIGURE 3. REAR VIEW OF PPM INSTRUMENT**



**OUTPUT CONNECTOR PIN ASSIGNMENT:**

**SCREW TERMINAL OUTPUT CONNECTOR**



TOP OF THE UNIT ↑

<u>PIN NO</u>	<u>DESCRIPTION</u>
1	LIMIT 1 COMMON/OPEN COLLECTOR POSITIVE
2	LIMIT 1 NORMALLY OPEN/OPEN COLLECTOR NEGATIVE
3	LIMIT 2 COMMON/OPEN COLLECTOR POSITIVE
4	LIMIT 2 NORMALLY OPEN/OPEN COLLECTOR NEGATIVE
5	LIMIT 3 COMMON/OPEN COLLECTOR POSITIVE
6	LIMIT 3 NORMALLY OPEN/OPEN COLLECTOR NEGATIVE
7	LIMIT 4 COMMON/OPEN COLLECTOR POSITIVE
8	LIMIT 4 NORMALLY OPEN/OPEN COLLECTOR NEGATIVE
9	TIMER 1 COMMON/OPEN COLLECTOR POSITIVE
10	TIMER 1 NORMALLY OPEN/OPEN COLLECTOR NEGATIVE
11	TIMER 2 COMMON/OPEN COLLECTOR POSITIVE
12	TIMER 2 NORMALLY OPEN/OPEN COLLECTOR NEGATIVE
13	HOLD/TARE or +5VDC Supply (See Model No. for option)
14	GROUND RETURN FOR HOLD/TARE & Optional 5Vdc Supply

# TROUBLE SHOOTING

If the meter locks on a particular display, unplug and plug in again the meter to unlock the display.

A total reset defaults all scaling values to zero. To perform this reset, re-apply power with **RESET** key pressed in.

Factory preset values for Current, Voltage and millivolt, respectively, can be programmed by simply re-apply power with either **^v**, **RATE** or **TARE** key pressed in. Respective default values are for CURRENT, VOLTAGE and MILLIVOLT inputs are:

## *Factory default settings for voltage, current and millivolt:*

<u>PARAMETER</u>	<u>CURRENT INPUT</u>	<u>VOLTAGE INPUT</u>	<u>MILLIVOLT INPUT</u>
HIGH SCALE	20.000	10.000	100.00
LOW SCALE	0.000	0.000	0.000
OFFSET	0.00	0.00	0.00
TARE	0.000	0.000	0.000
LIMITS	1.000	1.000	1.000

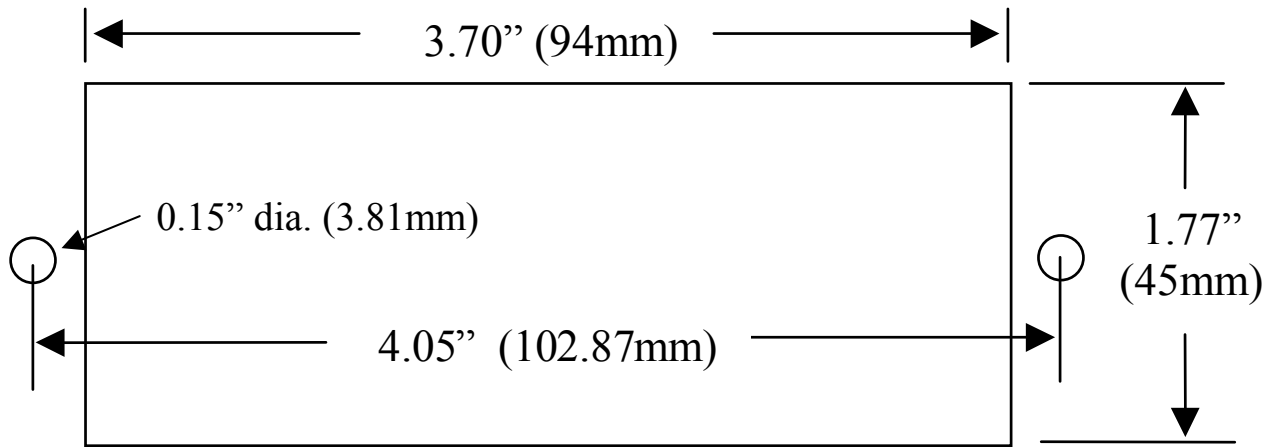
## *Error Messages:*

Various error messages indicated on the display are interpreted as below:

### ERROR MESSAGES AND SOLUTIONS

ERROR MESSAGE	ERROR CONDITION	SOLUTION
'EE ERROR'	The unit was unable to save programmed value in EEPROM -- possible failure of EEPROM.	If the message keeps coming up, unplug the unit and reapply power. If the unit still displays the error message, send it in for repair.  If the error message followed by 8.8.8.8.8. and the revision number are displayed occasionally, it is an indication that the power line is very noisy and needs a power line filter.
'PIO ERR'	Analog to digital converter error or keyboard processing error.	See above

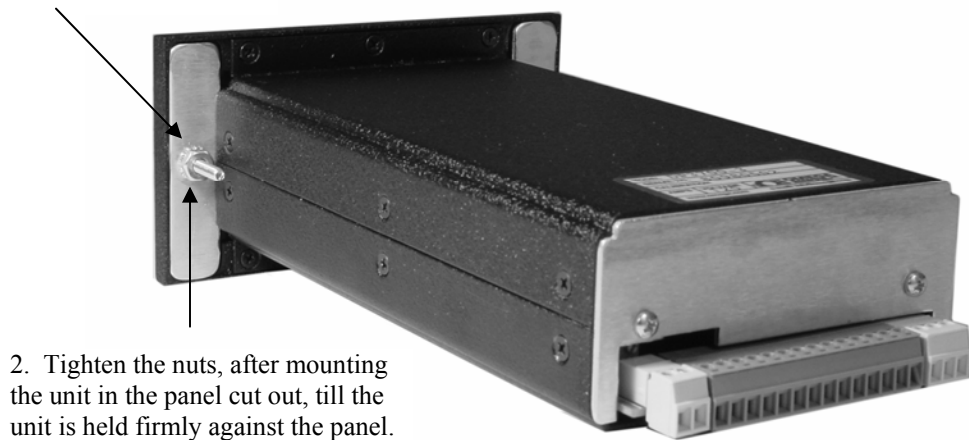
# MOUNTING



**Figure 4. Panel Cutout Dimensions**

1. Cut out Panel and mounting hole dimensions as shown in figure 8 above.
2. Remove the nuts from the mounting screws on the Panel Meter (see picture below).
3. Insert panel meter into the hole until it is flush with the panel.
4. Install the nuts and tighten them till the unit is held firmly against the panel.

1. Remove nuts and insert Panel Meter and screws in mounting holes in the panel cut out.



## WARRANTY

All products manufactured by Kaif Digital Corporation are warranted against defective material and workmanship for a period of one year from the date of shipment.

Any defective equipment returned to Kaif Digital Corporation (transportation charges prepaid) during the warranty period will be repaired or replaced free of charge provided there is no evidence of abuse or mishandling.

All products returned to Kaif Digital Corporation must be insured by sender and must be carefully packaged and adequately protected to prevent breakage from shock and rough handling that might occur during shipment. All applicable shipping charges, insurance, duties, and taxes must be prepaid by sender.

If, during the period of this warranty, the product appears to have a defect in material or workmanship, please call your local Kaif Digital representative or write:

Customer Service Department

Kaif Digital Corporation  
7678 E. Greenway Road, #103  
SCOTTSDALE, AZ 85260.

Tel: (480) 607-3100/Ext 201  
Fax: (480) 607-3101